

NETZSCH

Proven Excellence.

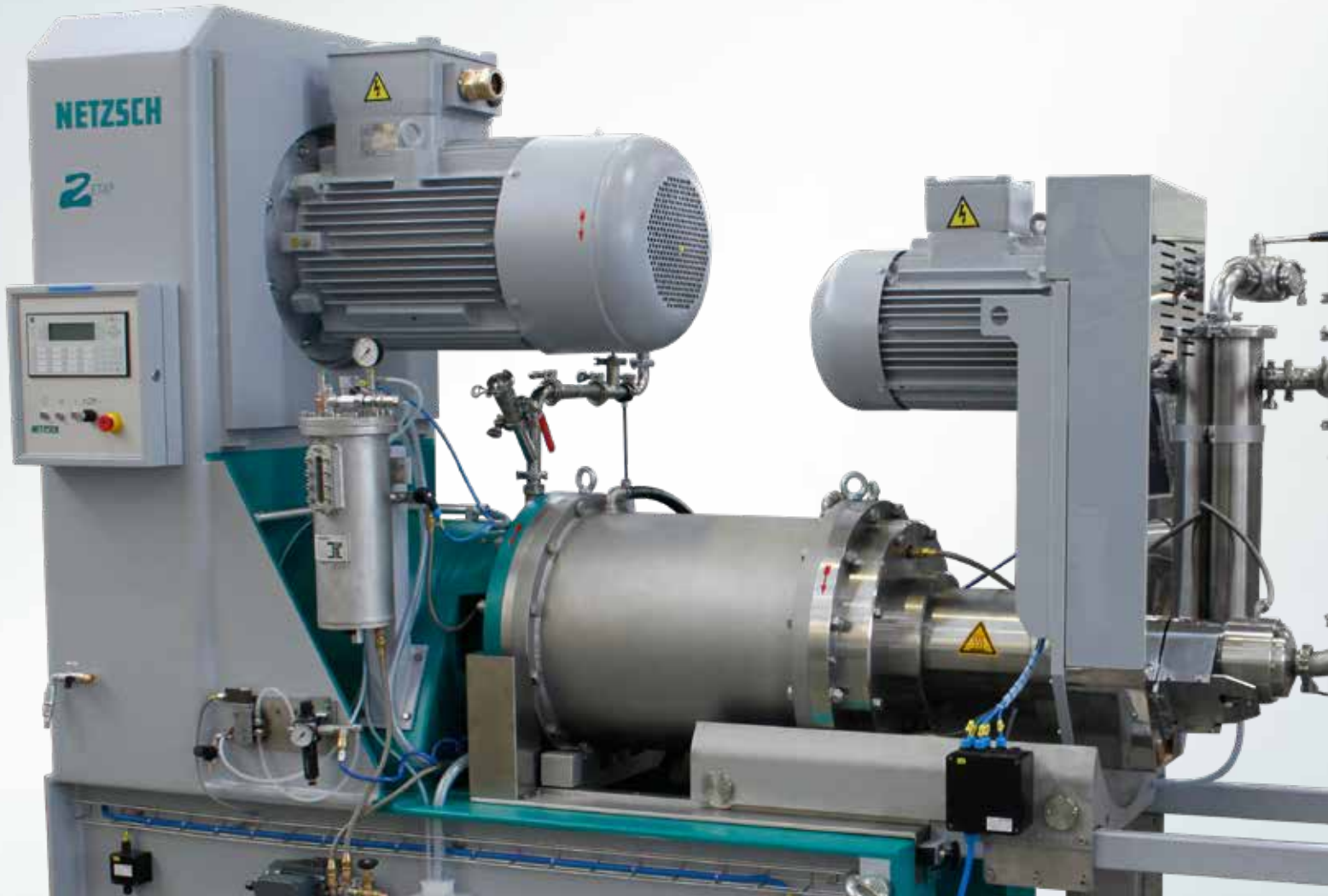

Innovation in Nanotechnology - ZETA[®] RS

For the use of Micro Grinding Beads

Business Unit
GRINDING & DISPERSING



ZETA[®] RS High-performance Mill

The future begins today

The demand for materials with particle sizes in the range far below 1 μm is steadily growing. This is due to the function-oriented benefits that these materials bring to the finished product.

In the colloidal particle size range, it is important to distinguish between true comminution, dsagglomeration and disaggregation. While with true comminution of coarse primary particles, compression and impact loads must be transferred to them, these direct loads often damage them during dispersion of agglomerated nanoscale primary particles that are present.

The reason for this is that the mechanical properties of the product particles change from brittle-elastic to plastic behavior as the particle size decreases. Transitions from a crystalline to amorphous material structure or mechanochemically-induced reactions can negatively affect the product properties.

Therefore, specifically designed equipment is required for the dispersion of nanostructured systems or for the production of nanoscale particles.

Handling

During development of the ZETA® RS machine series, special emphasis was placed on ease of use. Filling and emptying as well as servicing and cleaning the machine are easily accomplished without the loss of grinding media.

- Positionable grinding tank
- Integrated, removable grinding media collection tray
- For even greater usability, an optional swivel-mounted grinding chamber is available for models ALPHA® LAB ZETA® RS to ZETA® RS 10

Filling Position



Operating Position



Emptying and Cleaning Position



Grinding System & Mode of Operation

Grinding System

The *ZETA*[®] *RS* series agitator bead mills were developed for the use of so-called micro grinding beads (30 µm - 300 µm). This was achieved through the adaptation of the geometric dimensions of the NETZSCH System *ZETA*[®] circulation mill and the use of innovative separation systems.

- Peg grinding system with small length/diameter ratio and high power density
- Highly effective centrifugal separation systems
- The grinding media retention systems can be selected according to the product requirements

Mode of Operation

With the *ZETA*[®] *RS* agitator bead mills, products can be processed in a wide range of conditions, from gentle dispersion (4 m/s - 6 m/s) to very high energy densities (16 m/s - 20 m/s), in passage or circulation operation.

Separation Systems, Convertibility & Ma

Separation Systems

High throughput rates in circulation operation and the use of micro grinding media in the range of 30 μm - 300 μm are necessary for dispersion and true comminution into the nanometer range and place special demands on the grinding media retention system. The advanced centrifugal separation system can be constructed either as a rotating screen or, in a patented ODC (Open Dynamic Classifier) or SDC (Separately Driven Open Dynamic Classifier) version, it can be screen-free.

ODC System

- The ZETA® RS can be operated with an ODC (Open Dynamic Classifier) system, which is a screen-free, large-scale separation unit centrally located in the peg agitator, which rotates at the same speed as the peg agitator.

SDC System

- The ZETA® RS can also be operated with an SDC (Separately Driven Open Dynamic Classifier) system, which has a separate drive.
- The peripheral speed of the grinding media separation system can be set independently of the peripheral speed of the agitator shaft.
- This system was developed for the use of very small grinding media and low peripheral speeds of the agitator shaft.

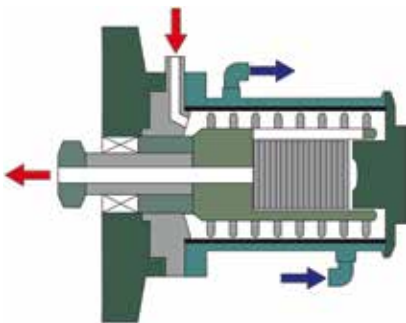

Rotating Screen System

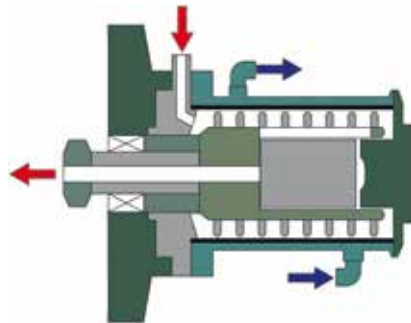

Open Dynamic Classifier (ODC) system

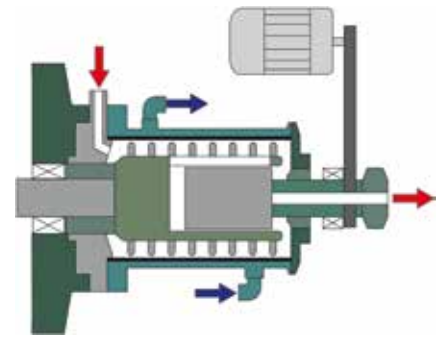

Separately Driven Open Dynamic Classifier (SDC) system

Material Options

Convertibility

For the preparation of smaller product quantities, a special conversion kit was developed that facilitates very quick conversion of the *ZETA*[®] *RS* 4, with a grinding chamber volume of 4 l, to the grinding chamber of the smaller *ZETA*[®] *RS* 2, with a volume of 2 l. Two easy-to-install adapter rings guarantee accommodation of the smaller-diameter grinding tank and the agitator shaft.

Grinding Chamber Materials

The *ZETA*[®] *RS* series machines are available in various wear- and corrosion-resistant materials in proven NETZSCH quality for metal-free fine grinding.

- NETZSCH-*CERAM* Z, NETZSCH-*CERAM* N or NElast in various grades for the peg agitator
- NETZSCH-*CERAM* C, NETZSCH-*CERAM* Z or NElast in various grades for the grinding tank liner

Advantages

- Processing of suspensions with coarse agglomerates is possible
- No loss of grinding beads when starting and stopping the machine
- No escape of grinding media even at high throughput rates
- Discharge of impurities and coarse product particles
- With optional configuration for the use of different separation systems, easy conversion from rotating screen to ODC or SDC system

Technical Data

	<i>ALPHA[®] LAB ZETA[®] RS</i>	<i>ZETA[®] RS 2</i>	<i>ZETA[®] RS 4</i>	<i>ZETA[®] RS 10</i>
Stand Design	swiveling	swiveling or non-swiveling		
Scale-up Factor	0.1	0.3	0.5	1
Drive Power [kW]	3.0	15	15	25
Speed [min ⁻¹]	1 000 - 4 500	500 - 2 250	500 - 2 250	250 - 1 600
Grinding Chamber Volume [l]	< 1	2	4	10
Grinding Bead Diameter [μm]	30 - 300			
Installed Motor Power [kW] SDC, optional	2.2	3.0	5.5	5.5

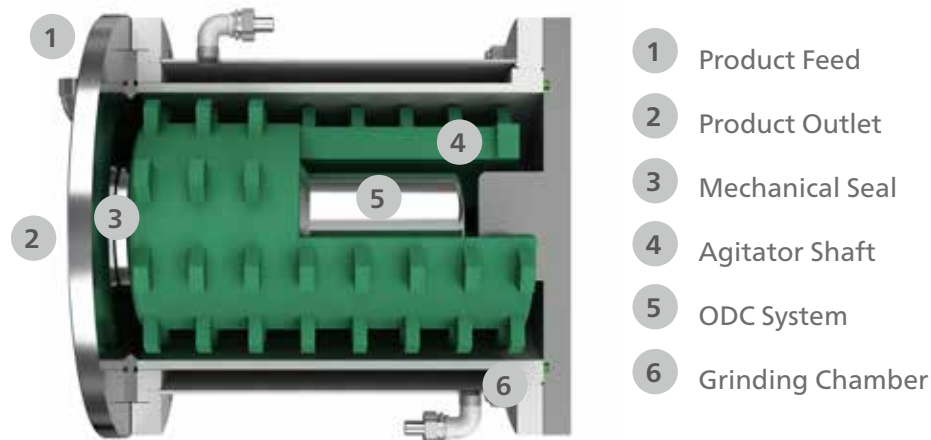

ZETA® RS 25	ZETA® RS 60
non-swiveling	
2	4
45	90
250 - 1500	150 - 900
25	60
7.5	18.5

Advantages at a Glance

- Compact design for minimum space requirement
- Easy handling with swiveling grinding unit and sliding grinding tank
- Prevention of grinding media loss, very easy cleaning and ease of use
- Reliable use of micro grinding beads in the range of 30 µm - 300 µm
- No screen blockage thanks to the ODC/SDC separation system
- Variety of materials available for grinding systems (can be interchanged)
- Large selection of grinding chamber materials (can be combined)

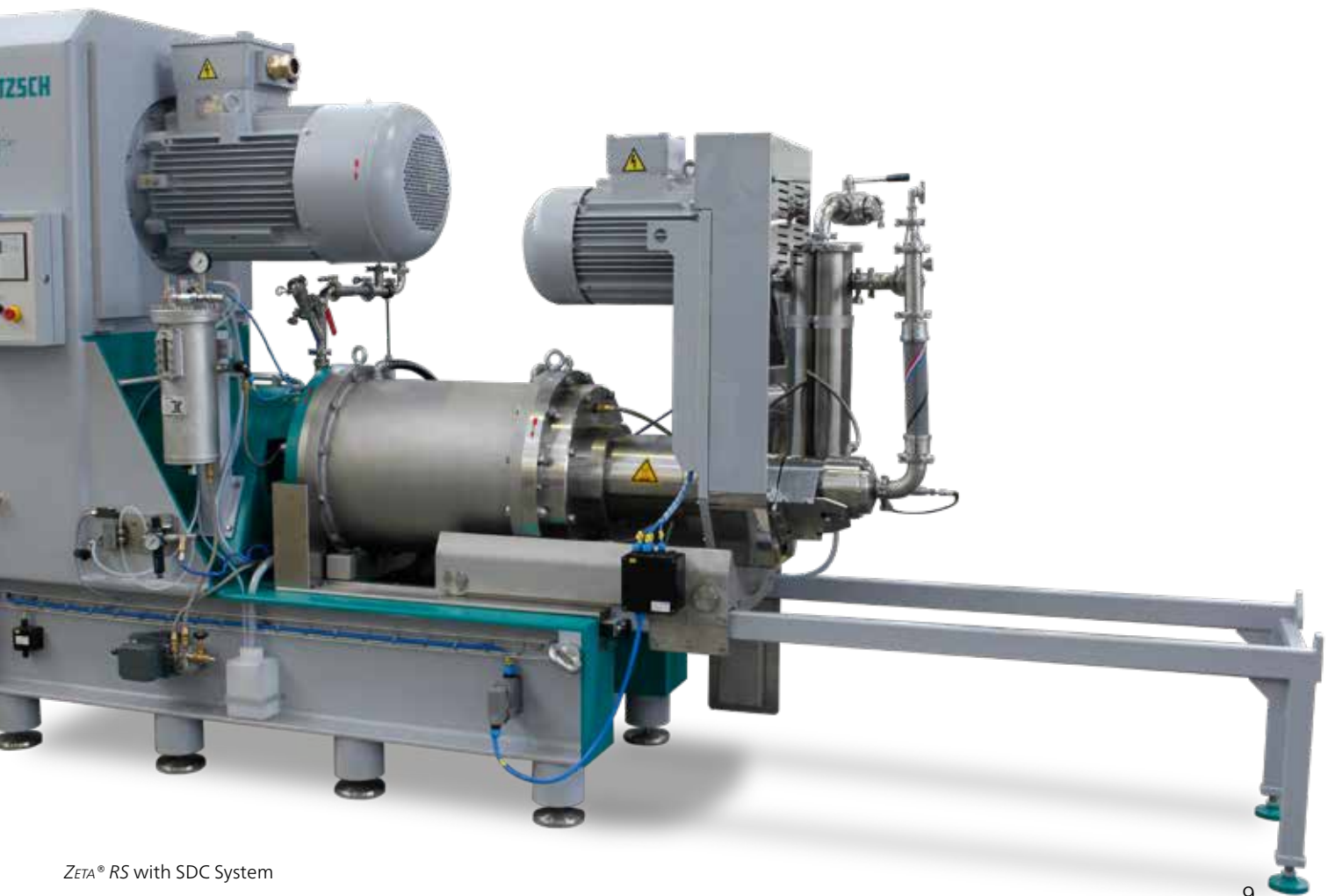

ZETA® RS with SDC System

ALPHA[®] LAB ZETA[®] RS Laboratory Mill

With the new ALPHA[®] LAB laboratory agitator bead mill, the concept of the new generation of agitator bead mills, first introduced in 2015 with the ALPHA[®] platform, has been systematically carried over to the laboratory mill. During redesign of the machine stand, special attention was given to ease of use and ergonomics. The grinding chamber of the ALPHA[®] LAB ZETA[®] RS is swivel-mounted so that filling with grinding media, emptying the grinding system with minimal hold-up and discharging the grinding media after the run all involve the least possible effort. In addition, different grinding systems (*DISCUS*, *ZETA*[®], *NEOS*) can be used with the ALPHA[®] LAB ZETA[®] RS laboratory agitator bead mill. Here, very little time is required to easily switch between the grinding systems, which are available in different materials and grinding chamber sizes (*MINI* and *MICRO*). The complete system for supply-

ing the mechanical seal with barrier fluid is easily accessible. This means that with frequent product changes, changing the barrier fluid is more convenient and less time consuming. The arrangement of the control panel has been optimized. The layout of the machine control is clearer and more concise. Standard with the new ALPHA[®] LAB ZETA[®] RS laboratory agitator bead mill is the interface required to access NETZSCH Connect, the database-centered tool that is controlled via web browser. Another new feature is that the ALPHA[®] LAB ZETA[®] RS is the first laboratory machine equipped with a screen-free, separately-driven, open, dynamic classifier system (SDC) for the separation of grinding media with a diameter of 0.03 mm - 0.3 mm. This means that a scale-up-capable solution for small product batches is now available for development work on the nanometer scale.

Unlimited Flexibility

The possible variations of the multifunctional *ALPHA*® *LAB ZETA*® *RS* laboratory mill offer yet another feature. In addition to the different scale-up-capable grinding systems in a variety of material options, the machine can also be converted to the smaller grinding chamber designs of the *MINISERIES* with a 230 ml capacity and the *MICROSERIES* with a 110 ml capacity. A special conversion kit that facilitates short installation times was developed for this purpose.

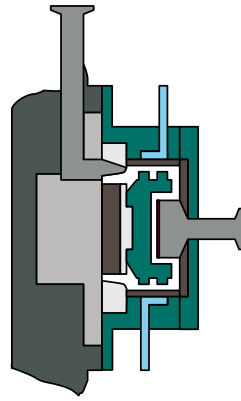

LABSTAR conversion kit on the *MICROSERIES*

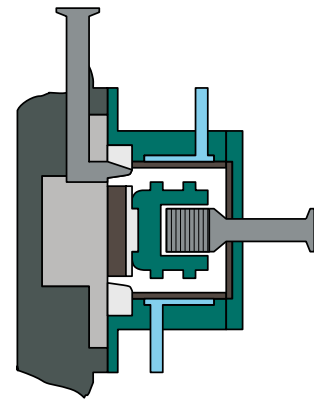

LABSTAR conversion kit on the *MINISERIES*



Monitoring & Control

The control system of the ZETA® RS high-performance mill facilitates efficient and automatic process control. Acquisition of the energy input, temperature and pressure along with the existing safety functions, enables automatic operation by which preselected parameters start up automatically.

NETZSCH GRAPH offers various control strategies, the measured values are graphically assigned to the test points on the display, each formula can be processed automatically according to individual parameters. In addition, we offer integration into higher-level control systems as well as data acquisition hardware and software – contact our specialists.

NETZSCH GRAPH

- Display of operation, input and calculation parameters:
 - Mill speed and peripheral speed, gross and net mill power, pump speed, product pressure, product throughput, product temperature and process status
- Display of trend graphics for the most essential operating data
- Process data memory (set points and limits for max. 98 product data sets)
- Automatic operation with transfer of the process parameters from the data memory
- Selectable operating mode
- Selectable control strategies:
 - Control of power, temperature, pressure or throughput – flow meter required
- Shut-off functions can be selected and combined:
 - Timer
 - Energy input and/or number of passes
 - Pressure-dependent shut-off during passage operation
- Control and fault lamps as well as
- Control unit with local/remote selector switch (functionality optional)
- Automatic screen-cleaning sequence

Data Acquisition

The data acquisition system serves to record the values measured by a machine and comprises the hardware required to transfer the existing measurements via an Ethernet connection and the software for installation on a PC.

The measured and input data are stored in a CSV file and the current measured values are displayed. The acquisition rate can be pre-set by the operator to intervals ranging from 1 s to 10 min. After successful data acquisition, further evaluation is possible in a spreadsheet program.

Your Benefits

- High operational reliability
- Various control methods
- Quality assurance through energy input
- Automatic screen-cleaning sequence
- Maximum machine utilization through control of the agitator speed as a function of the product discharge temperature
- Pre-selection of the power input through adjustment of the agitator shaft speed
- Speed adjustment possible via frequency converter
- Easy integration into plants and higher-level process control systems

ZETA[®] RS Nanomill

Applications

ZETA[®] RS Series machines can be used in gentle dispersion, but also for the true comminution of a wider range of products, such as pigments, pigment preparations, Inkjet, MLCC, functional coatings, nano ceramics and many more. The following table shows an overview of dispersion results for various applications in which gentle conditions were used for processing.

Product	Applications	Grinding bead material	Grinding bead diameter	Peripheral speed	Particle size x ₅₀ achieved
Pigment	LCD	ZrO ₂ (Y ₂ O ₃)	0.1 mm	6 m/s	40 - 60 nm
Pigment	Inkjet	ZrO ₂ (Y ₂ O ₃)	0.1 mm	6 m/s	13 nm
TiO ₂	Photocatalyst	ZrO ₂ (Y ₂ O ₃)	0.03 mm	6 m/s	22 nm
ITO	Electronics	ZrO ₂ (Y ₂ O ₃)	0.1 mm	6 m/s	44 nm
ZrO ₂	Electronics	ZrO ₂ (Y ₂ O ₃)	0.05 mm	4 m/s	37 nm
Diamond	Polishing agent	ZrO ₂ (Y ₂ O ₃)	0.1 mm	10 m/s	19 nm
BaTiO ₃	MLCC	Glass	0.1 mm	3 m/s	200 nm
SiO ₂	Paper	Glass	0.1 mm	8 m/s	40 nm
ZnO	UV Protections	ZrO ₂ (Y ₂ O ₃)	0.1 mm	12 m/s	18 nm

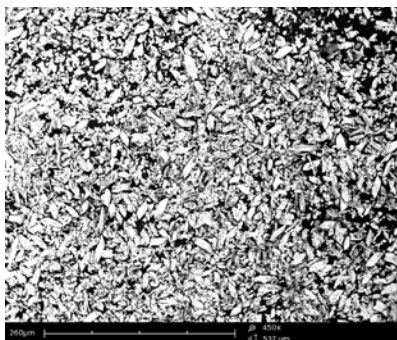

Lithium iron phosphate before

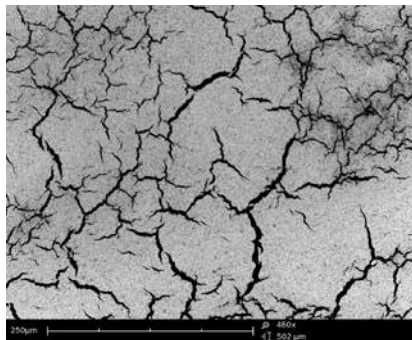

Lithium iron phosphate after

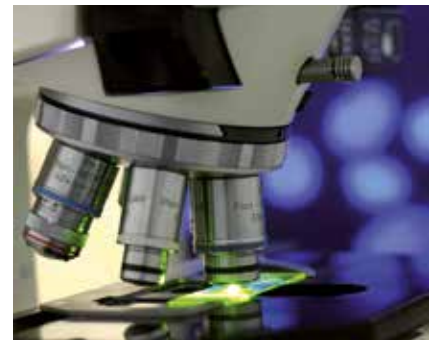

Applications

Process Technology for Battery Applications

The natural reserves of non-renewable energy sources as well as increasing pollution and global warming, triggered for example by CO₂ emissions from the burning of fossil fuels such as coal, gas or oil, are forcing people to change their views.

Increasingly, forms of renewable energy such as solar, wind and thermal energy or electrical power from hydroelectric power plants are covering our daily power needs. However, these renewable energy sources are not always available at any time. They are dependent on the weather, the time of day and the time of year. In addition, the times for peak consumption and the generation rates do not generally coincide.

One material of interest in the development of increasingly efficient energy storage is metallic silicon. The silicon is usually contamination-free, with median values below 100 nm and narrow particle size distribution required to facilitate the best possible performance of the battery.

With the ZETA® RS, large quantities of silicon can be ground down to the required particle size in accordance with the quality criteria, regardless of the source of the raw materials. Owing to the separately driven open dynamic classifier system (SCD) and the all-ceramic equipment, a reliable process with minimum maintenance is possible.





Gentle Dispersion

Nano-structured TiO₂ particles for use in photo catalytic coatings were dispersed using different agitator speeds (4 m/s and 13 m/s).

It was not possible to achieve the desired degree of dispersion with an agitator speed of 13 m/s. Furthermore, it was found that the coatings made from this material were photo-catalytically inactive.

Examinations with X-ray diffraction analysis showed that, contrary to gentle dispersing, the crystalline lattice structure of the TiO₂ was destroyed due to the high-energy loads.

Therefore, agglomerates of nanoscale primary particles should be stressed mainly by shearing under "gentle" conditions, which requires the use of extremely small grinding beads at very low agitator speeds in the agitator bead mill.

When the suspension was dispersed at 4 m/s, the desired dispersion result was achieved with the same energy input. The crystalline structure of the product was preserved.

NETZSCH-Feinmahltechnik GmbH developed the ZETA® RS generation of mills for these complex tasks.

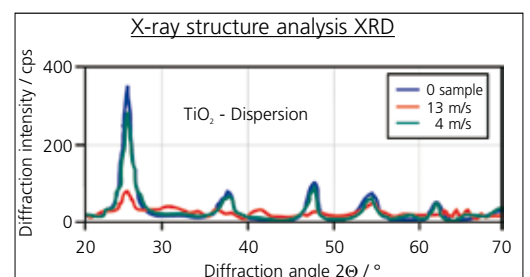
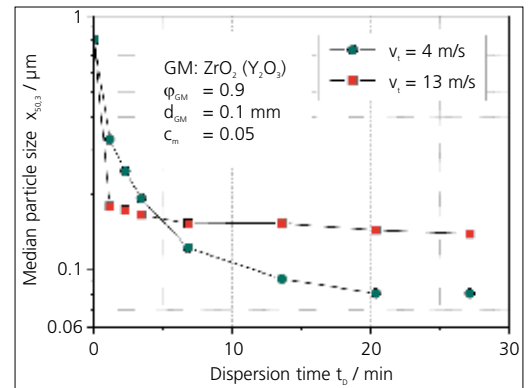
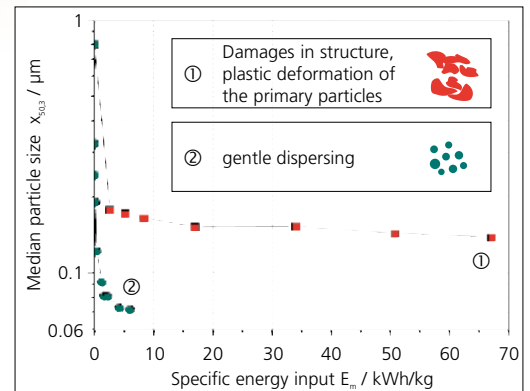

Applications

Gentle Dispersion & True Comminution: Example using Titanium Dioxide

True Comminution of Titanium Dioxide for Functional Coatings

For the production of functional coatings, titanium dioxide was prepared as an aqueous suspension with a particle size $x_{90,3}$ below 100 nm. Two grinding tests were carried out in a *ZETA® RS 4* agitator bead mill (4 liter grinding chamber volume). This mill has a centrifugal separation system with rotating separator, which can be equipped with a screen or an open dynamic classifying system (ODC).

Yttrium-stabilized zirconium oxide grinding beads with a diameter of 0.2 mm - 0.3 mm were used for Test A. The grinding beads were separated by a rotating slotted pipe in the mill. Test B was carried out with closely fractioned yttrium-stabilized zirconium oxide grinding beads with a diameter of 0.1 mm. To prevent a pressure increase at the suspension inlet of the mill, the ODC separator system was used here. All other operating parameters were identical. The test results can be seen in the plot.

For comminution with larger grinding media (Test A), the desired result was achieved after a grinding time of 5 h and a specific energy input of 1.2 kWh/kg. By using smaller grinding beads (Test B) the same result was achieved in only 45 min and 0.2 kWh/kg of the energy input.

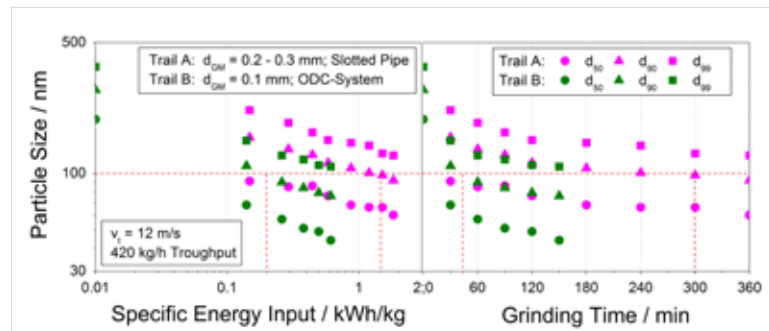

Your Benefit

- Possible to use different sizes and shapes of grinding media without changing the slotted pipe
- No contamination due to metal abrasion
- Significantly lower pressure buildup in the mill: thus higher throughputs are possible
- Reduction in the size of the grinding media through wear during long periods of operation is not a problem
- Grinding beads that deviate from the spherical shape can be used
- The ODC system can be completely disassembled and is easy to clean

Your Testing Options with the *ZETA*[®] *RS* Nanomill

Machines

NETZSCH-Feinmahltechnik GmbH has a state-of-the-art technical center available to its customers for extensive testing at the company headquarters in Selb. At the *ZETA*[®] *RS* 2, *ZETA*[®] *RS* 4 and *ZETA*[®] *RS* 25 test stations, we can demonstrate dispersion, disaggregation or true comminution of your nanoscale products.

Analysis

Comprehensive methods of analysis are available to determine comminution and dispersion success as well as changes in the rheological properties of the product suspensions.

- **Malvern Mastersizer 3000**
Static light scattering combined with laser defraction, measuring range 10 nm to 3500 µm.
- **Malvern Zetasizer Nano ZS**
Dynamic light scattering, particle size determination and zeta potential determination in one measuring cell, measuring range 0.6 nm to 6 µm.
- **Malvern Kinexus Rotationsrheometer**
Universal rheometer for all basic rheological testing – viscosity, oscillation rheology, creep and relaxation tests, continuous torque range from 0.05 µNm to 200 mNm.
- **Jeol JSM-6490 LV**
Scanning electron microscope with up to 100,000x magnification, for imaging samples and powders, including elemental analysis with X-ray microanalysis from Thermo Scientific.





NETZSCH-BEADS®

Ceramic Grinding Beads

The selection of suitable grinding media is a key optimization feature for dispersion and wet grinding processes with agitator mills. With the use of NETZSCH-BEADS® you'll achieve optimum results.

In particular, our ZETABEADS® NANO yttrium-stabilized zirconium oxide grinding media (high-end quality) are ideal for your nano applications.



The NETZSCH Group is an owner-managed, international technology company with headquarters in Germany. The Business Units Analyzing & Testing, Grinding & Dispersing and Pumps & Systems represent customized solutions at the highest level. More than 4 000 employees in 36 countries and a worldwide sales and service network ensure customer proximity and competent service.

Our performance standards are high. We promise our customers Proven Excellence – exceptional performance in everything we do, proven time and again since 1873.

Proven Excellence. ■

Business Unit Grinding & Dispersing – The World's Leading Grinding Technology

NETZSCH-Feinmahltechnik | Germany
NETZSCH Trockenmahltechnik | Germany
NETZSCH Vakumix | Germany
NETZSCH Lohnmahltechnik | Germany
NETZSCH Mastermix | Great Britain
NETZSCH FRÈRES | France
NETZSCH España | Spain
ECUTEK | Spain

NETZSCH Machinery and Instruments | China
NETZSCH India Grinding & Dispersing | India
NETZSCH Tula | Russia
NETZSCH Makine Sanayi ve Ticaret | Turkey
NETZSCH Korea | Korea
NETZSCH Premier Technologies | USA
NETZSCH Equipamentos de Moagem | Brazil

NETZSCH-Feinmahltechnik GmbH
Sedanstraße 70
95100 Selb
Germany
Tel.: +49 9287 797-0
Fax: +49 9287 797 149
info.nft@netzsch.com

NETZSCH®

www.netzsch.com